

TYRE TECHNICAL FORM

FICHE TECHNIQUE DU PNEUMATIQUE



Manufacturier	Tyre Manufacturer	VEGA S.p.A.
Marque	Make	VEGA
Modèle	Model	SLICK CA 11x5.00-5
Nombre de pages	Number of pages	4

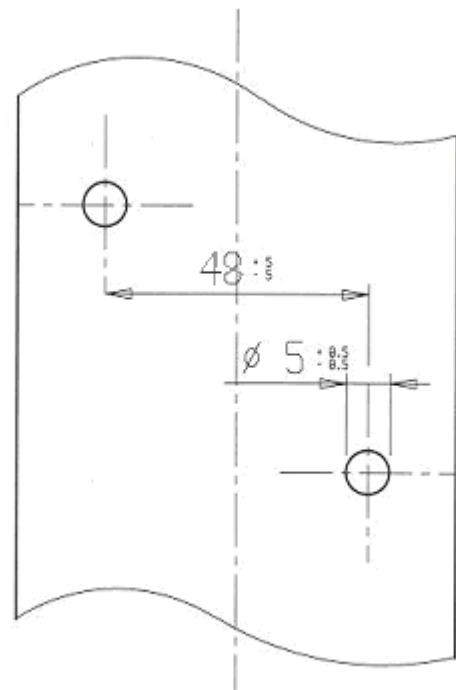
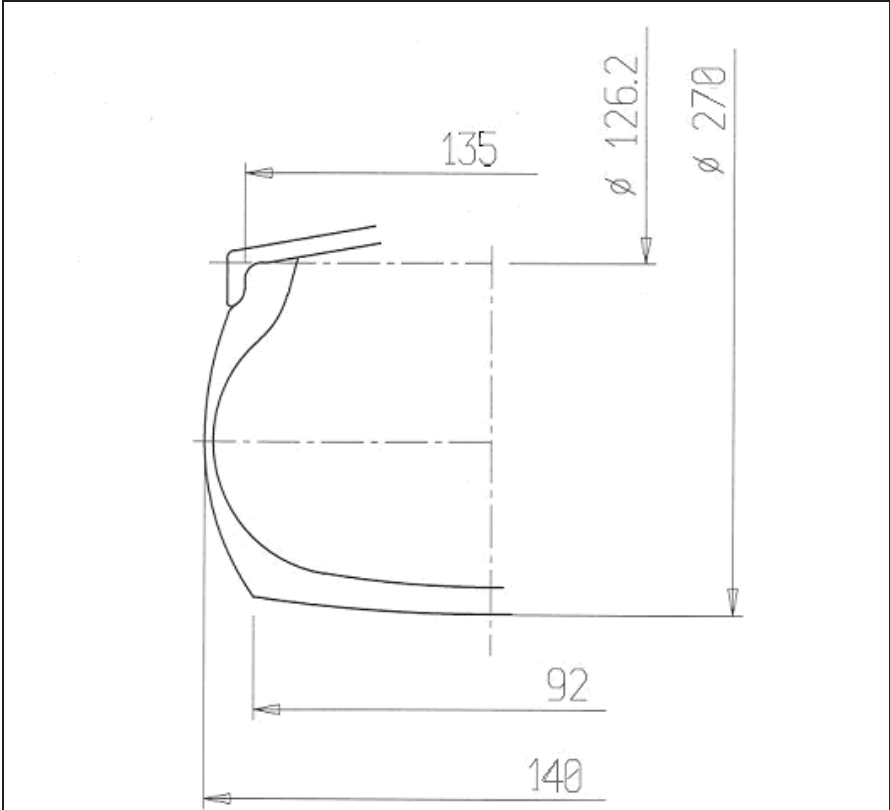
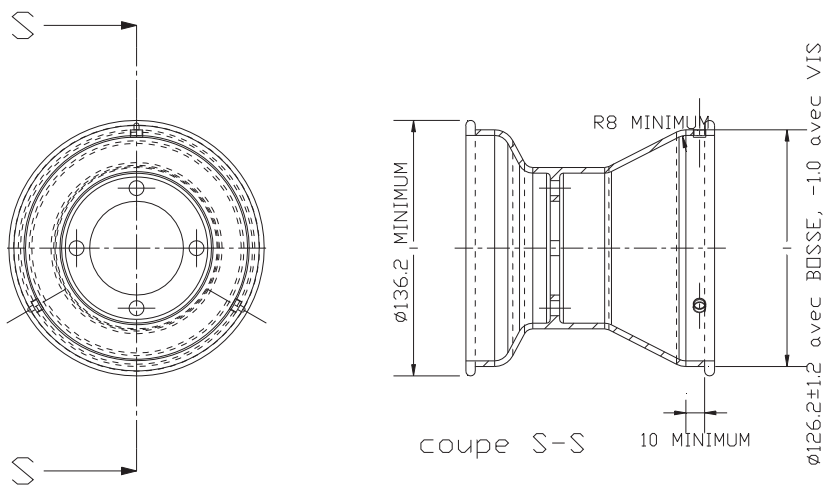



PHOTO DU PNEU MONTÉ SUR LA JANTE
PHOTO OF THE TYRE FITTED TO THE RIM

DESSIN DE LA BANDE DE ROULEMENT
TREAD DESIGN DRAWING

DESCRIPTIONS TECHNIQUES		TECHNICAL DESCRIPTIONS				
Sous une température de 23°C +/- 2°C, avec une humidité de 50% +/-5%		At a temperature of 23°C +/- 2°C and with a humidity of 50% +/-5%				
	Descriptions	Descriptions	Valeurs		Tolérances	
	Dimensions	<i>Dimensions</i>	11x5.00-5		-	
2	Désignation du mélange	<i>Tread compound designation</i>	CA		-	
3	Pression de Service	<i>Service pressure</i>	1,1 bar		+/- 0,3 bar	
4	Pression de gonflage maximum	<i>Maximum inflation pressure</i>	4 bar		Max	
5	Capacité de charge maximum	<i>Maximum load capacity</i>	100 Kg		Max	
6	Vitesse maximale	<i>Maximum speed</i>	150 Km/h		Max	
7	Rigidité latérale et verticale (sous charge de 40 kg)	<i>Lateral and vertical spring stiffness (under load of 40 kg)</i>	1,5 – 17		+/- 1 +/- 2	
8	Rigidité latérale et verticale pour FE et ICE (sous charge de 50 kg)	<i>Lateral and vertical stiffness for FE & ICE (under load of 50 kg)</i>	-		-	
9	Profondeur du profil	<i>Depth of tread</i>	5,5 mm		+/- 0,5 mm	
10	Poids en grammes	<i>Weight in grams</i>	1180 gr		+/- 5%	
11	Nombre de plis	<i>Numbers of plies</i>	2		-	
12	Épaisseur de la bande de roulement	<i>Tread thickness</i>	6 mm		+/- 1,0 mm	
13	Nombre d'indicateurs d'usure du pneu	<i>Number of tread wear indicators</i>	6		-	
14	Matériel de la carcasse	<i>Carcass material</i>	Nylon		-	
15	Angle de tissage de la toile du pneu	<i>Angle of tyre canvass</i>	33°		+/- 3°	
16	Type du fil de tissage (Selon ISO)	<i>Canvass thread type (According to ISO)</i>	942		-	
17	Pneu tubeless	<i>Tubeless tyre</i>	YES		-	
18	Dureté superficielle de la bande de roulement (ISO 48/94)	<i>Superficial tread hardness (ISO 48/94)</i>	69		+/- 5 DIDC IRHD	
19	Contrainte-déformation en traction (ISO 37/94)	<i>Tensile stress-strain (ISO 37/94)</i>	At 100%	At 300%	At 100%	At 300%
			1.90	8.10	+/- 3 MPa	
20	Abrasion en rotation (selon ISO 4649/02 Method B)	<i>Circular abrasion (according to ISO 4649/02 Method B)</i>	-		-	
21	Classification (selon ISO 37:2005 – 300%)	<i>Classification (according to ISO 37:2005 – 300%)</i>	SOFT	MEDIUM	HARD	

B	DESSIN EN SECTION TRANSVERSALE ET MESURES DU PNEU MONTÉ SUR UNE JANTE	B	DRAWING OF CROSS SECTION AND DIMENSIONS OF TYRE FITTED TO A RIM	
			Tolérances Tolerances	
			mm	mm
			Diam. 126,2	+ 0 - 1
			Diam. 270	+/- 6
			135	+/- 3
			92	+/- 5
			140	+/- 5
			Remarques Comments	



C	PHOTOS ET INSCRIPTIONS	Seules les inscriptions qui ne changeront pas tout au long de la fabrication sont reportées ci-dessous.		
C	PHOTOS AND INSCRIPTIONS	Only inscriptions which will not change during production are mentioned below.		
Photo du flanc extérieur du pneu Photo of tyre external side wall		Inscriptions sur le flanc extérieur du pneu <i>Inscriptions on tyre external side wall</i>		
		Texte Text	Hauteur Height	Trait Stroke
		▲ VEGA	mm 12.7	mm 4
		11x5.00-5	12.7	4
		tubeless	6,2	1,5
		KART	12,7	4
		→	35	4
Photo du flanc intérieur du pneu Photo of tyre internal side wall		Inscriptions sur le flanc intérieur du pneu <i>Inscriptions on tyre internal side wall</i>		
		Texte Text	Hauteur Height	Trait Stroke
		▲ VEGA	12.7	4
		11x5.00-5	12.7	4
		Max inflation pressure 4 bar	3,8	1
		For racing purpose only	3,8	1
		KART	12,7	4
→	35	4		