

# FICHE D'HOMOLOGATION HOMOLOGATION FORM

58 /P/10



## COMMISSION INTERNATIONALE DE KARTING - FIA



### PNEUMATIQUE / TYRE

Manufacturier	<i>Tyre Manufacturer</i>	VEGA S.p.A.
Marque	<i>Make</i>	VEGA
Modèle	<i>Model</i>	SLICK XP 11x7.10-5
Catégorie	<i>Category</i>	GROUPE 1&2 / GROUP 1&2
Durée de l'homologation	<i>Validity of the homologation</i>	3 ANS / YEARS
Nombre de pages	<i>Number of pages</i>	4
Nombre de pages annexes	<i>Number of appended pages</i>	

La présente Fiche d'Homologation reproduit descriptions, illustrations et dimensions du pneumatique au moment de l'homologation CIK-FIA. Le Manufacturier a la possibilité de les modifier seulement dans les limites fixées par le règlement CIK-FIA en vigueur.

*This Homologation Form reproduces descriptions, illustrations and dimensions of the tyre at the time of the CIK-FIA homologation. The Tyre Manufacturer may modify them, but only within the limits laid down by the CIK-FIA regulations in force.*

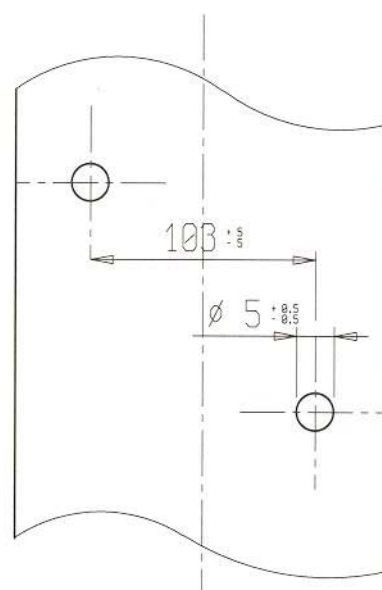

PHOTO DU PNEU MONTÉ SUR LA JANTE  
PHOTO OF THE TYRE FITTED TO THE RIM

DESSIN DE LA BANDE DE ROULEMENT  
TREAD DESIGN DRAWING

Signature et tampon de l'ASN  
*Signature and stamp of the ASN*

Signature et tampon de la CIK-FIA  
*Signature and stamp of the CIK-FIA*

DESCRIPTIONS TECHNIQUES			TECHNICAL DESCRIPTIONS			
Sous une température de 23°C +/- 2°C, avec une humidité de 50% +/-5%			At a temperature of 23°C +/- 2°C and with a humidity of 50% +/-5%			
Pt	Descriptions	Descriptions	Valeurs		Tolérances	
1	Dimensions	<i>Dimensions</i>	11 x 7.10 - 5		-	
2	Désignation du mélange	<i>Tread compound designation</i>	XP		-	
3	Pression de service	<i>Service pressure</i>	0,6 bar		+/- 0,3 bar	
4	Pression de gonflage maximum	<i>Maximum inflation pressure</i>	4 bar		Max	
5	Capacité de charge maximum	<i>Maximum load capacity</i>	100 Kg		Max	
6	Vitesse maximale	<i>Maximum speed</i>	200 Km/h		Max	
7	Rigidité latérale et verticale (sous charge de 40 kg)	<i>Lateral and vertical stiffness (under 40 kg load)</i>	1,0 – 19		+/- 1 +/- 2	
8	Rigidité latérale et verticale pour SK et ICE (sous charge de 50 kg)	<i>Lateral and vertical stiffness for SK &amp; ICE (under 50 kg load)</i>	-		+/- 1 +/- 2	
9	Profondeur du profil	<i>Depth of tread</i>	4 mm		+/- 0,5 mm	
10	Poids en grammes	<i>Weight in grams</i>	1680		+/- 10%	
11	Nombre de plis	<i>Numbers of plies</i>	2		-	
12	Épaisseur de la bande de roulement	<i>Tread thickness</i>	5 mm		+/- 1,0 mm	
13	Nombre d'indicateurs d'usure du pneu	<i>Number of tread wear indicators</i>	6		-	
14	Matériel de la carcasse	<i>Carcass material</i>	Polyestere		-	
15	Angle de tissage de la toile du pneu	<i>Angle of tyre canvass</i>	34°		+/- 3°	
16	Type du fil de tissage (Selon ISO)	<i>Canvass thread type (According to ISO)</i>	1670		-	
17	Pneu tubeless	<i>Tubeless tyre</i>	YES		-	
18	Dureté superficielle de la bande de roulement (ISO 48/94 – 2 échantillons de 2mm d'épaisseur)	<i>Superficial tread hardness (ISO 48/94 – 2 samples of 2mm thickness)</i>	41		+/- 5 DIDC - IRHD	
19	Contrainte-déformation en traction (ISO 37:2005 – éprouvette type 3)	<i>Tensile stress-strain (ISO 37:2005 – type 3 sample)</i>	At 100%	At 300%	At 100%	At 300%
			0.79	3.10	+/- 0.5 MPa	+/- 0.8 MPa
20	Classification (selon ISO 37:2005 – 300%)	<i>Classification (according to ISO 37:2005 – 300%)</i>	SOFT	<del>MEDIUM</del>	<del>HARD</del>	

**58 /P/10**

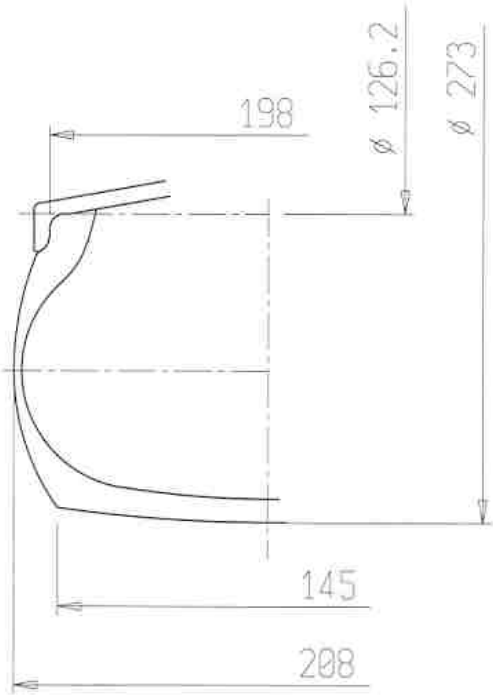
B	DESSIN EN SECTION TRANSVERSALE ET MESURES DU PNEU MONTÉ SUR UNE JANTE	B	DRAWING OF CROSS SECTION AND DIMENSIONS OF TYRE FITTED TO A RIM																																		
			<table border="1" style="width: 100%; border-collapse: collapse;"> <thead> <tr> <th colspan="2" style="text-align: center;">Tolérances Tolerances</th> </tr> <tr> <th style="text-align: center;">mm</th> <th style="text-align: center;">mm</th> </tr> </thead> <tbody> <tr> <td style="text-align: center;">Diam. 126,2</td> <td style="text-align: center;">+ 0 - 1</td> </tr> <tr> <td style="text-align: center;">Diam. 273</td> <td style="text-align: center;">+/- 6</td> </tr> <tr> <td style="text-align: center;">198</td> <td style="text-align: center;">+/- 3</td> </tr> <tr> <td style="text-align: center;">208</td> <td style="text-align: center;">+/- 5</td> </tr> <tr> <td style="text-align: center;">145</td> <td style="text-align: center;">+/- 5</td> </tr> <tr> <td> </td> <td> </td> </tr> <tr> <td> </td> <td> </td> </tr> <tr> <td> </td> <td> </td> </tr> <tr> <td> </td> <td> </td> </tr> <tr> <td> </td> <td> </td> </tr> <tr> <td> </td> <td> </td> </tr> <tr> <td> </td> <td> </td> </tr> <tr> <td> </td> <td> </td> </tr> <tr> <td colspan="2" style="text-align: center;">Remarques Comments</td> </tr> <tr> <td colspan="2"> </td> </tr> </tbody> </table>	Tolérances Tolerances		mm	mm	Diam. 126,2	+ 0 - 1	Diam. 273	+/- 6	198	+/- 3	208	+/- 5	145	+/- 5																	Remarques Comments			
Tolérances Tolerances																																					
mm	mm																																				
Diam. 126,2	+ 0 - 1																																				
Diam. 273	+/- 6																																				
198	+/- 3																																				
208	+/- 5																																				
145	+/- 5																																				
Remarques Comments																																					

**Jante 5" standardisée / Standardised 5" rim**

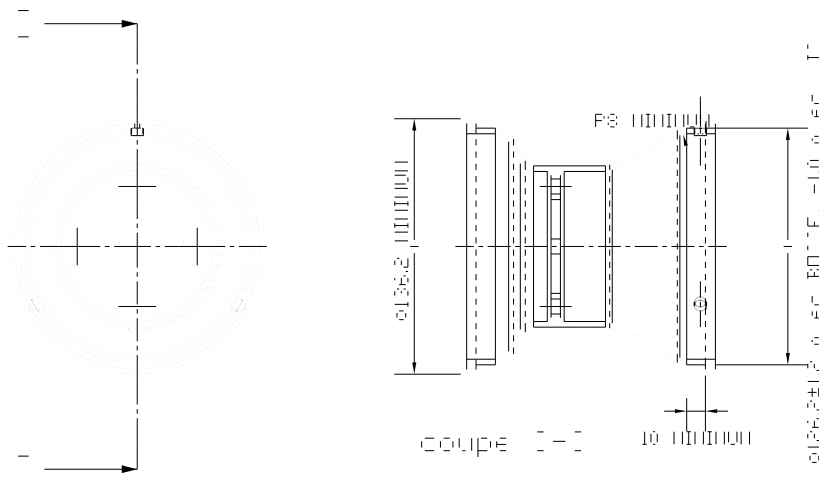

C	PHOTOS ET INSCRIPTIONS	Seules les inscriptions qui ne changeront pas tout au long de la fabrication sont reportées ci-dessous.		
C	PHOTOS AND INSCRIPTIONS	<i>Only inscriptions which will not change during production are mentioned below.</i>		
Photo du flanc extérieur du pneu <i>Photo of tyre external side wall</i>		Inscriptions sur le flanc extérieur du pneu <i>Inscriptions on tyre external side wall</i>		
		Texte <i>Text</i>	Hauteur <i>Height</i>	Trait <i>Stroke</i>
			mm	mm
		VEGA (printed)		
		KART >>	9,5	3
		11x7.10-5	6,5	3
	Max inflation pressure 4 bar	3,8	1	
Photo du flanc intérieur du pneu <i>Photo of tyre internal side wall</i>		Inscriptions sur le flanc intérieur du pneu <i>Inscriptions on tyre internal side wall</i>		
		Texte <i>Text</i>	Hauteur <i>Height</i>	Trait <i>Stroke</i>
			mm	mm
		VEGA	13	3 / 8
		11x7.10-5	6,5	3
		XP	9,5	3,5
		CIK - S	6,5	3
		made in Italy	3,8	1
		For racing purpose only	3,8	1
tubeless	3,8	1		